

26th Annual
ACBL-wide

2012
Instant
Matchpoint
Game



Thursday evening
October 4

Dear Bridge Players,

I'm honored to have been invited back for the sixth straight year to write the analysis for the 2012 ACBL Instant Matchpoint Game. The mere fact that you are reading this tells me that you are interested in learning more about our wonderful game of bridge. Reading the analysis of deals you've just played is in my opinion, the best way to learn. We all make mistakes; to understand why, and to get it right next time puts you on the road to becoming a better player.

The best and worst part of this event is the "instant matchpoints." It's nice to get your score immediately (instant gratification). On the down side, there is always griping about the matchpoint table. There will be complaints — that's a prerequisite for being a competitive bridge player. But, I can assure you, that these matchpoint scores are taken from more than 1,000 results per board when these deals were played long ago. Yes, they were played by your fellow human beings that supposedly were not playing bridge for the first time. Hopefully, the good and bad matchpointing evened out for you. Unfortunately, there are many deals where you might sit there and do nothing wrong and get 10 or 20%. If this happened on too many deals, you didn't have a very good score (but I hope you still had a good time).

The analysis presumes a "Standard American 2/1 GF" approach with basic conventions such as Negative Doubles, Stayman, Jacoby Transfers, Keycard Blackwood (although very few deals this year required conventions). The notrump range is 15-17; I apologize in advance to all the weak notrumpers out there who won't get to see the auction matching their methods. Once again, this set of deals (I didn't choose them) proves that having a lot of methods and conventions is not too important. These are randomly dealt computer deals from a session played overseas a decade ago.

I hope you enjoy the analyses herein, and maybe, for once, you can prove to your partner that he was wrong and you were right. If you'd like to contact me, or read any of the bridge articles/features I've written, you can do so through my website at www.larryco.com



Larry Cohen



Larry Cohen of Boca Raton FL is one of the leading players, teachers, and writers in the bridge world. He won 26 North American Championships before semi-retiring from tournament play in 2009. He has taught at land and sea all over the world and was listed in ACBL's most influential 52 all-time bridge people. His books have been translated into eight languages; he is best known for his best seller on the LAW of Total Tricks. He is a contributor to many bridge magazines, including two columns in ACBL's Bridge Bulletin (The Real Deal, and It's Your Call). Larry conducts teaching bridge cruises (intermediate level) every year and gives lectures all over the country (details at <http://www.larryco.com> – which has lots of free bridge articles and instruction).

Board 1

Dealer: N	♠ 102		
Vul: None	♥ 52		
	♦ 109874		
	♣ K874		
♠ A75			♠ 9864
♥ J986			♥ AK1073
♦ K63			♦ 2
♣ Q32			♣ 965
	♠ KQJ3		
	♥ Q4		
	♦ AQJ5		
	♣ AJ10		

<i>West</i>	<i>North</i>	<i>East</i>	<i>South</i>
—	Pass	Pass	2NT
Pass	Pass	Pass	

MATCHPOINT TABLE	
N-S Score	Match- points
...	100
500	99
...	98
210	97
...	96
170	95
...	94
140	93
130	93
120	89
110	84
100	81
90	80
80	79
70	78
50	78
-50	62
-100	31
-110	14
-140	13
-150	8
-200	1
...	0

We start with an auction likely to occur at most tables (North has to be really hungry to act over 2NT). Unfortunately for North-South, hearts aren't stopped and that is the suit West will lead. The defense has five hearts (West would have to be really sleepy to block the suit) and the ♠A. Also, they have many ways to arrange to score the ♦K for down two. After the ♥AK, West can signal with the 9 — his medium heart for the medium suit. Or, on the fifth heart, West can signal for a diamond (he has the right spot cards with which to signal regardless of what carding East-West use). The difference between down one and down two is huge.

Board 2

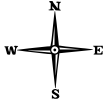
Dealer: E	♠ 74	
Vul: N-S	♥ AK983	
	♦ 9862	
	♣ AJ	
♠ AKQJ1098		♠ 52
♥ J4		♥ Q52
♦ Q		♦ A5
♣ 1084		♣ KQ9762
	♠ 63	
	♥ 1076	
	♦ KJ10743	
	♣ 53	

MATCHPOINT TABLE	
N-S Score	Match-points
...	100
300	99
...	98
100	96
50	90
-100	85
...	84
-170	82
-200	79
...	78
-420	47
-430	16
-450	9
-480	2
...	0

<i>West</i>	<i>North</i>	<i>East</i>	<i>South</i>
—	—	1 ♣	Pass
1 ♠	Pass	2 ♣	Pass
4 ♠	Pass	Pass	Pass

Most players (especially at favorable vulnerability) open the East cards. West is too strong for an immediate jump to 4♠. Better is to bid 1♠ then 4♠ to show more strength. The vulnerability should prevent South and then North from entering the auction. On North's normal ♥K lead, South gives a signal (to deny a doubleton). North might switch to diamonds to try to set up a fourth defensive trick, but on the actual layout, nothing matters. It is hard to imagine a score other than 420 East-West, but a look at the matchpoint table shows all the things that could go wrong.

Board 3

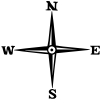
Dealer: S	♠ 97654		
Vul: E-W	♥ K10		
	♦ A10982		
	♣ 10		
♠ A8			♠ K3
♥ 54			♥ Q98762
♦ Q7643			♦ —
♣ A832			♣ QJ974
	♠ QJ102		
	♥ AJ3		
	♦ KJ5		
	♣ K65		

<i>West</i>	<i>North</i>	<i>East</i>	<i>South</i>
—	—	—	1NT
Pass	2♥	Pass	2♠
Pass	??		

MATCHPOINT TABLE	
N-S Score	Match-points
...	100
800	99
...	98
590	97
...	96
450	95
430	93
420	77
...	61
200	59
180	58
170	53
140	44
130	40
...	39
90	38
...	37
-50	23
-100	6
-110	5
...	4
-170	3
...	2
-750	1
...	0

After a 15-17 1NT, West should not come in (even if he can bid 2♣ to show clubs and another suit) at these colors. North transfers to spades (East might double to show hearts) and then has a decision (shown by the question marks). He can make a conservative pass, or an aggressive 3♦. The problem with the latter is that is game forcing. It would be nice to find an “in-between” action; maybe some North players will start with Stayman, intending to bid 2♠ next to show this type of hand. When they hear 2♠ in response, they can change their minds, and bid 4♠. If North passes 2♠, East should balance (I like 2NT to show any two-suiter). The North-South spade game isn’t bad, but the 5-0 diamond break is troublesome. West might easily lead a diamond, but even on a heart lead, declarer is likely to fail in game. The deal actually belongs to East-West (they can make 4♥!), but it will be rare for them to declare.

Board 4

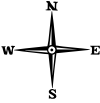
Dealer: W	♠ A10643		
Vul: Both	♥ J2		
	♦ AQ4		
	♣ J82		
♠ 97		♠ KQJ52	
♥ A10873		♥ K9	
♦ 865		♦ K92	
♣ K97		♣ A53	
	♠ 8		
	♥ Q654		
	♦ J1073		
	♣ Q1064		

<i>West</i>	<i>North</i>	<i>East</i>	<i>South</i>
—	1♠	1NT	Pass
2♦	Pass	2♥	All Pass

MATCHPOINT TABLE	
N-S Score	Match-points
...	100
300	99
...	97
180	96
...	95
120	94
100	88
...	83
-80	82
-90	80
-100	77
-110	70
-120	58
-140	47
-150	39
-170	33
-180	31
-200	24
-210	19
-300	15
-400	10
-500	9
-600	7
-630	5
...	4
-800	2
-870	1
...	0

East might trap pass and hope to collect a penalty (at 100 a trick). However, most will overcall 1NT. West might invite after transferring (since a vulnerable 1NT overcall can be on the heavy side). If East plays in 2♥ the defense is not clear. If North wins the ♠A to play another spade, he should continue with the 10 for two reasons: One, suit preference for diamonds and two, to smother dummy's 9 (preventing declarer from playing low). South can get his ruff and another trump trick. The defense can also get the ♦A and likely one other minor-suit trick, making 110 East-West a likely result. West actually does best to pass 1NT, where declarer can take at least eight tricks providing he doesn't misguess hearts.

Board 5

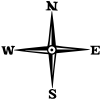
Dealer: N Vul: N-S	♠ AQ32 ♥ J742 ♦ 7532 ♣ A	♠ J74 ♥ K8 ♦ KQJ10 ♣ 10942
♠ K85 ♥ 63 ♦ A9864 ♣ QJ7		
	♠ 1096 ♥ AQ1095 ♦ — ♣ K8653	

<i>West</i>	<i>North</i>	<i>East</i>	<i>South</i>
—	1♦	Pass	1♥
Pass	2♥	Pass	4♥
Pass	Pass	Pass	

MATCHPOINT TABLE	
N-S Score	Match-points
...	100
1430	99
...	98
990	97
...	96
790	95
...	94
680	82
650	67
620	63
500	62
...	61
230	55
200	49
170	44
150	40
140	38
...	37
100	35
50	32
0	16
...	2
-100	1
...	0

Should North open? There is no correct answer. In favor is that there are 2 ½ quick tricks and there are no rebid problems. Against it is the lack of good spot cards and the unfavorable vulnerability. The trend (most of today's winners agree) is to open on the light side, so I've shown a 1♦ opening which leads to a straightforward auction to 4♥. South has enough shape to insist on game after getting raised. If North doesn't open, the deal could be passed out, but South should open light in third seat with 1♥ over which North might use Drury and eventually insist on game. With the friendly lie of the cards, it is very normal to take 12 tricks (declarer draws trump, ruffs two clubs in dummy and loses only one spade trick). East-West will surely be complaining about the matchpoint results here. Plus 680 North-South should occur at most tables, so it will be a huge disappointment to East-West to receive only 18% — where is the field protection? Apparently the field doesn't reach 20-HCP games. Even a heart partial making 12 tricks is inexplicably above average for North-South — apparently many tables passed the deal out.

Board 6

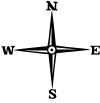
Dealer: E Vul: E-W	♠ 82 ♥ A9864 ♦ J74 ♣ Q92		♠ KJ95 ♥ K1073 ♦ 96 ♣ AJ8
♠ 10763 ♥ J ♦ KQ852 ♣ K104	♠ AQ4 ♥ Q52 ♦ A103 ♣ 7653		

MATCHPOINT TABLE	
N-S Score	Match-points
...	100
300	99
...	98
200	93
...	92
100	84
90	76
...	75
-50	74
-70	73
-90	61
-100	48
-110	45
-120	33
-130	23
-140	17
-150	7
-170	3
...	2
-200	1
...	0

<i>West</i>	<i>North</i>	<i>East</i>	<i>South</i>
—	—	1 ♣	Pass
1 ♠	Pass	2 ♠	Pass
Pass	Pass		

Almost everyone opens East's hand. Some Souths could enter with a takeout double (taking advantage of the favorable vulnerability). It is unusual, though, to make a takeout double when your longest suit is the opponent's suit! If South doubles, North might eventually compete too high. In the auction shown, where South passes, West bids 1 ♠. In the modern style, the diamonds are bypassed with a "one-bid" hand; West uses his one speaking opportunity to name the major. East raises and it's hard to see North or South getting into the auction at this late juncture. Declarer will lose two spades and two red aces — but might take the rest due to the fortunate lie of the diamonds. Plus 140 for East-West earns them most of the matchpoints.

Board 7

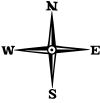
Dealer: S	♠ 5		
Vul: Both	♥ Q75		
	♦ J8752		
	♣ QJ73		
			
♠ QJ943		♠ A10876	
♥ 1043		♥ 982	
♦ 6		♦ K1043	
♣ 6542		♣ 9	
	♠ K2		
	♥ AKJ6		
	♦ AQ9		
	♣ AK108		

MATCHPOINT TABLE	
N-S Score	Match-points
...	100
1440	99
1430	98
...	97
1370	96
...	95
910	97
690	84
680	72
660	62
650	50
640	46
630	31
620	15
600	12
500	10
...	9
-100	5
-200	1
...	0

<i>West</i>	<i>North</i>	<i>East</i>	<i>South</i>
—	—	—	2♣
Pass	2♦	Pass	2NT
Pass	3NT	All Pass	

How does South show 24 balanced HCP? He starts with 2♣ but has a dilemma (unless using something called “Kokish”) on his next turn. A 2NT rebid shows 22-23, maybe 24. A 3NT rebid shows a good 24 to 25/26. This hand is right on the cusp. Some South’s might go big and rebid 3NT, over which North might consider a move towards slam (maybe even 5NT, pick-a-slam). Over the 2NT rebid shown, North will likely be content to just bid game. After the normal spade lead and continuation, declarer has 10 top tricks. If he cashes out, he gets a below average board. More likely is to cash nine winners ending in dummy for a diamond finesse (by the point it is taken, the contract is assured. Also, West will have shown up with a lot of black cards, making the diamond finesse more than a 50% bet). North-South pairs reaching the poor slam (in clubs or notrump) can make it if they take a double diamond finesse.

Board 8

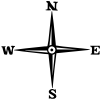
Dealer: W Vul: None	♠ KJ43 ♥ Q75 ♦ KJ1087 ♣ 4	♠ Q972 ♥ J982 ♦ 42 ♣ A106
♠ A10 ♥ A63 ♦ 93 ♣ KQJ532		
	♠ 865 ♥ K104 ♦ AQ65 ♣ 987	

MATCHPOINT TABLE	
N-S Score	Match-points
...	100
300	99
...	98
150	95
130	92
110	85
100	70
90	62
50	52
-50	37
-80	31
-90	29
-100	25
-110	16
-120	9
-130	6
-140	4
...	2
-200	1
...	0

<i>West</i>	<i>North</i>	<i>East</i>	<i>South</i>
1NT	Pass	Pass	Pass

There are dozens of possible auctions on this competitive partscore deal; I've shown the simplest of them all. West's hand is on the heavy side for opening 1♣ planning to rebid 2♣, but I expect that will be the plan for the majority. With a good six-card suit, the hand is worth way more than the actual 14 HCP — I'd say it is worth 16 or 17. It is relatively balanced, thus the 1NT opening. North surely might intervene (playing DONT he could bid 2♦ to show diamonds and a major). If North passes, East might use Stayman, but that would leave him poorly placed if opener answered 2♦. If West opens 1♣, North overcalls 1♦, East doubles and South raises diamonds (using whatever system bid fits his hand). With best play and defense East-West can make nine tricks in clubs while North-South can make nine in diamonds.

Board 9

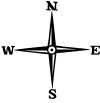
Dealer: N Vul: E-W	♠ Q108 ♥ J1075 ♦ — ♣ AJ10863		♠ 97642 ♥ 98 ♦ J9854 ♣ 2
♠ KJ53 ♥ K642 ♦ K62 ♣ Q5	♠ A ♥ AQ3 ♦ AQ1073 ♣ K974		

<i>West</i>	<i>North</i>	<i>East</i>	<i>South</i>
—	Pass	Pass	1♦
Pass	1♥	Pass	3♣
Pass	5♣	Pass	6♣
Pass	Pass	Pass	

MATCHPOINT TABLE	
N-S Score	Match-points
...	100
1090	99
990	98
980	98
940	97
920	84
800	75
...	74
490	72
480	70
460	65
450	60
440	58
430	54
420	34
400	18
...	16
180	15
170	12
...	9
100	8
90	7
-50	5
-80	3
...	2
-300	1
...	0

North should not preempt with such good prospects (especially in the majors) on the side. If he does happen to open 3♣, South would likely bid 6♣ directly. When North passes (at most tables), South opens 1♦ and North shows his major (instead of the clubs). South is worth a game-forcing jump-shift (he is intending to raise hearts next). North loves clubs and could bid 4♣ (already in a game force) or 5♣ as shown (this jump shows great trumps — but I'd be a little afraid as North that my hand is too good). While there might be a grand slam, South has to be concerned that he is missing the ♣A Q and both red kings; partner can't possibly fill all those holes. In 6♣, declarer can't misguess trumps, but will have to lose the heart finesse. Any East-West pair who happens to get only 16% for minus 920, will just have to hope the matchpointing evens out in the long run.

Board 10

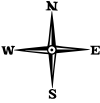
Dealer: E Vul: Both	♠ KJ32 ♥ K964 ♦ Q93 ♣ 108	♠ AQ8654 ♥ A ♦ AJ84 ♣ Q5
♠ 1097 ♥ Q10752 ♦ K5 ♣ A73		
	♠ — ♥ J83 ♦ 10762 ♣ KJ9642	

<i>West</i>	<i>North</i>	<i>East</i>	<i>South</i>
—	—	1 ♠	Pass
2 ♠	Pass	4 ♠	All Pass

MATCHPOINT TABLE	
N-S Score	Match-points
...	100
500	99
...	98
200	97
...	96
100	95
50	92
...	91
-170	90
-200	88
-210	87
-230	86
...	84
-600	83
-620	76
-630	67
-650	50
-660	34
-680	21
-690	7
-710	6
-790	5
-800	4
...	3
-1100	2
-1130	1
...	0

After East's opening, South would like to preempt, but the vulnerability is wrong. West is perfectly within range for 2♠, but a bit on the high side. East has too much playing strength to mess around — he should just jump to the spade game (without giving any information to the defense). South has a tough lead problem; all three suits are possible. The most helpful leads for declarer are (in order) clubs, diamonds, hearts. On any lead, declarer should try to ruff diamonds in dummy and then will make a spade play. Most likely is low to the queen, after which declarer can still handle the trump suit for only one loser (he can get back to dummy to lead a second round). One likely occurrence (after a heart lead) is ♦K, ♦A, diamond ruff, spade to the queen, club to the ace, spade covered, spade. Now North can put South in with the ♣K to ruff the fourth diamond.

Board 11

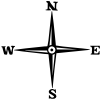
Dealer: S Vul: None	♠ Q82 ♥ AK52 ♦ A76 ♣ A105	♠ 1094 ♥ Q76 ♦ KQ1032 ♣ K4
♠ 753 ♥ 10943 ♦ 95 ♣ J863		
	♠ AKJ6 ♥ J8 ♦ J84 ♣ Q972	

MATCHPOINT TABLE	
N-S Score	Match-points
...	100
490	99
460	92
450	84
430	61
420	38
400	29
180	20
...	19
150	18
...	17
-50	14
-100	7
-150	2
...	0

<i>West</i>	<i>North</i>	<i>East</i>	<i>South</i>
—	—	—	1 ♣
Pass	1 ♥	Pass	1 ♠
Pass	2 ♦	Pass	2NT
Pass	3NT	All Pass	

Yes, most players open hands such as Souths (even though the three jacks make it worth less than 12). North responds 1♥ (there is no rush to do anything else). Some South players skip the spades and rebid notrump, but that makes it hard to find a 4-4 spade fit. After South's 1♠, North used 2♦, the fourth-suit, as an artificial game force (it would be precipitous to do anything else). South now bids 2NT (in theory, this shows diamonds stopped, but J-x-x is good enough). North could invite with 4NT, but there isn't much point; South has shown a flat minimum — slam is no longer in the picture. West would like to make a safe, passive lead. Perhaps some East players will double the fourth suit (quite dangerous) to get a diamond lead. Even so, East can win his ♦Q, but won't be able to profitably return the suit. This is your classic notrump overtrick battle (with numerous possible lines of play and defense). All the matchpoints ride on whether or not declarer can take nine, 10 or 11 tricks.

Board 12

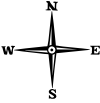
Dealer: W Vul: N-S	♠ K1083 ♥ QJ ♦ AKQ53 ♣ K7	♠ QJ92 ♥ 965 ♦ 107 ♣ QJ104
♠ A764 ♥ K32 ♦ J986 ♣ A2		
	♠ 5 ♥ A10874 ♦ 42 ♣ 98653	

<i>West</i>	<i>North</i>	<i>East</i>	<i>South</i>
1♦	1NT	Pass	2♦
Pass	2♥	All Pass	

MATCHPOINT TABLE	
N-S Score	Match-points
...	100
800	99
...	98
660	97
630	96
600	94
500	92
...	90
210	88
200	87
...	84
170	83
150	79
140	73
130	68
120	66
110	55
100	41
90	35
...	33
50	32
...	31
-100	22
...	13
-200	8
...	2
-300	1
...	0

It is the trend to open with hands such as West's. Most successful players agree with "opening all 12's." At this vulnerability, North's best choice is to enter (not trap pass). A 1NT overcall is the most descriptive action (though a takeout double is possible). Vulnerable against not, a 1NT overcall should be 15-plus to 18. South transfers to hearts and North will likely buy it there. Ostensibly, declarer has to lose only two aces and the ♥K. However, there are handling issues which could make it difficult to take 10 tricks. Making only nine for 140 is still quite a good result for North-South, and there isn't anything East-West can do to prevent it.

Board 13

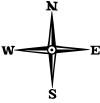
Dealer: N Vul: Both	♠ J4 ♥ AQJ65 ♦ A10752 ♣ 10		♠ Q75 ♥ K94 ♦ KQJ ♣ J987
♠ AK92 ♥ 8732 ♦ 643 ♣ K3	♠ 10863 ♥ 10 ♦ 98 ♣ AQ6542		

<i>West</i>	<i>North</i>	<i>East</i>	<i>South</i>
—	1♥	Pass	1♠
Pass	2♦	Pass	&#x24;#x27;@!

MATCHPOINT TABLE	
N-S Score	Match-points
...	100
800	99
...	98
300	97
200	94
...	93
130	92
120	91
110	84
100	75
90	67
80	59
...	58
-100	46
...	33
-150	32
-200	22
-300	9
-400	3
-500	1
...	0

I suppose South's second bid as shown is insufficient, but that's how I would feel. To avoid this problem, South could suppress the spades on round one and bid a forcing 1NT, to be followed by clubs. On the actual auction, South can't bid 3♣ (forcing) nor 2NT (encouraging). The least of evils is to pass, and fortunately it is a 5-2, not a 4-2 fit. This auction (dummy prefers declarer's second suit) screams for a trump lead and East's king-queen-jack are screaming as well. Actually, the hand plays well in diamonds. Declarer should not even try to ruff hearts in dummy. He should duck the trump lead and then play a low heart to utilize the power of dummy's ♥10. The defense will likely win and continue diamonds, but declarer will then play a third round himself. He loses only two spades, two diamonds and a heart to score plus 90. I guess South didn't have to swear after all.

Board 14

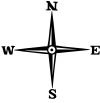
Dealer: E Vul: None	♠ Q2 ♥ 32 ♦ QJ3 ♣ AQ8654	♠ J984 ♥ AQJ7 ♦ K985 ♣ 2
♠ 73 ♥ 1054 ♦ 1074 ♣ J10973		
	♠ AK1065 ♥ K986 ♦ A62 ♣ K	

<i>West</i>	<i>North</i>	<i>East</i>	<i>South</i>
—	—	1♦	1♠
Pass	2♣	Pass	2♦
Pass	2♠	Pass	2NT
Pass	3NT	All Pass	

MATCHPOINT TABLE	
N-S Score	Match-points
...	100
500	99
...	98
490	97
460	92
450	87
430	75
420	62
400	47
...	35
210	34
200	33
180	33
170	30
150	28
140	25
130	22
120	21
110	20
100	20
80	19
-50	11
-100	1
...	0

The opening bids are deteriorating (in this booklet and in real life). Maybe half the Easts will pass in which case South opens 1♠ (after which, North could declare 3NT if he starts with 1NT forcing or semi-forcing). In the auction shown, South overcalls (more on target than double), North shows his clubs (it is up to the partnership if this is forcing) and South has enough for 3NT. However, with only A-x-x in the opponent's suit, there should be no rush to bid notrump. South bids a delicate 2♦ to probe, North admits to spade tolerance and now South can bid notrump. After a diamond lead, South will unblock the ♣K and go to dummy's ♠Q. When he learns of 5-1 clubs, he might take the spade finesse (after a low diamond lead, it will be clear that East is 4=4=4=1). This is a lot like Board 11, in that almost every North-South will play 3NT, with the matchpoints hinging on overtricks.

Board 15

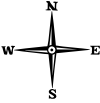
Dealer: S Vul: N-S	♠ 73 ♥ K1065 ♦ Q75 ♣ 9652	♠ AQ10 ♥ Q84 ♦ J104 ♣ AKQ4
♠ KJ9652 ♥ A72 ♦ A983 ♣ —		
	♠ 84 ♥ J93 ♦ K62 ♣ J10873	

MATCHPOINT TABLE	
N-S Score	Match-points
...	100
100	99
50	93
...	87
-420	86
-450	82
-460	77
-480	64
-490	51
-510	50
...	49
-980	28
-990	3
...	0

<i>West</i>	<i>North</i>	<i>East</i>	<i>South</i>
—	—	—	Pass
1 ♠	Pass	2 ♣	Pass
2 ♠	Pass	3 ♠	Pass
??			

After West's 1 ♠, there are many choices. East might have a conventional way to show a big balanced hand, but I like starting with 2 ♣ as shown (it leaves space). West could show his four-card minor, but most will rebid the six-card major as shown. Now, East is too strong for 4 ♠ (the 3 ♠ call assumes 2/1 game force) so it shows extra values. Now what? West has too nice a hand to sign-off in 4 ♠, so he should control-bid. Usually, these bids are made up-the-line, but many theorists don't like control-bidding shortness in a suit partner has shown. Using that theory, West might skip clubs and control-bid 4 ♦. East has lots of extras, but no heart control. Maybe he bids 5 ♣ (he shouldn't use Blackwood when he might be off the cashing ♥AK). I wish I could recommend "the" auction to 6 ♠, but there is no one correct way. Declarer has 11 top tricks and his best play for a 12th is to take two diamond finesses (roughly a 75% chance). Playing for the ♥K right will also work (throwing three diamonds on clubs) but that is only a 50% chance. The best contract is actually 6NT by East, and could be reached by some.

Board 16

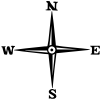
Dealer: W Vul: E-W	♠ 982 ♥ 92 ♦ J5 ♣ KQJ976	♠ J3 ♥ AJ8 ♦ Q109432 ♣ 42
♠ AK7654 ♥ KQ106 ♦ A8 ♣ 5		♠ Q10 ♥ 7543 ♦ K76 ♣ A1083

MATCHPOINT TABLE	
N-S Score	Match-points
...	100
300	99
...	98
200	94
100	86
-50	80
-100	79
...	79
-150	73
-170	65
-200	56
-230	54
-260	53
-300	53
-500	52
...	51
-620	36
-650	13
-660	5
-680	4
-710	3
...	2
-800	1
...	0

<i>West</i>	<i>North</i>	<i>East</i>	<i>South</i>
1 ♠	Pass	1NT	Pass
2 ♥	Pass	2 ♠	Pass
4 ♠	Pass	Pass	Pass

Many North players will take advantage of the favorable vulnerability to overcall 3♣. If that happens, South will maybe boost to 4♣, doubled by West. East might take this out to 5♦ and West will not be a happy camper (though the contract can make with a lucky guess). In the auction shown (North going peacefully), West introduces his hearts on the second round (he is not strong enough to jump-shift) and East takes a false preference. West is good enough to go directly to game. The best play in spades (though nothing matters on this layout) is low towards the jack on the first round of the suit. Declarer should lose a spade, club, and diamond for an easy 620 and a decent score.

Board 17

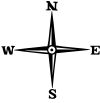
Dealer: N	♠ Q5	
Vul: None	♥ K764	
	♦ Q105	
	♣ AQJ4	
♠ K		♠ 9632
♥ A1082		♥ J5
♦ 64		♦ AKJ83
♣ 1097632		♣ 85
	♠ AJ10874	
	♥ Q93	
	♦ 972	
	♣ K	

MATCHPOINT TABLE	
N-S Score	Match-points
...	100
500	99
...	98
450	97
430	96
420	94
400	90
...	87
180	86
170	85
150	83
140	77
120	71
110	66
100	61
...	60
50	59
-50	44
-100	18
-150	4
-200	1
...	0

<i>West</i>	<i>North</i>	<i>East</i>	<i>South</i>
—	1♣	1♦	1♠
Pass	1NT	Pass	2♠
Pass	Pass	Pass	

After North's 1♣, East has enough (good suit) for a one-level overcall. South's 1♠ bid promises four or more (after a 1♥ overcall it would show five-plus). North has a normal 1NT rebid. South, facing 12-14 balanced, is probably not worth a game try. There is more to lose than to gain (opening bids are light these days, and 12 is statistically more likely than 14). After three rounds of diamonds, it isn't clear what East will do. He might play a heart after which declarer is likely to take a losing spade finesse to make eight tricks. Yes, declarer can drop the ♠K but why would he? And yes, East can play a fourth diamond to create a sure trick for the ♠K. As usual, if the side with the cards just does something resembling normal bridge, they get a decent score.

Board 18

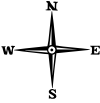
Dealer: E Vul: N-S	♠ Q643 ♥ AKQ4 ♦ A962 ♣ 9	♠ A92 ♥ 863 ♦ K1084 ♣ 432
♠ K875 ♥ J9752 ♦ 5 ♣ Q75		
	♠ J10 ♥ 10 ♦ QJ73 ♣ AKJ1086	

MATCHPOINT TABLE	
N-S Score	Match-points
...	100
690	98
660	90
630	76
600	50
...	32
150	30
...	29
-100	21
-200	9
-300	3
-400	1
...	0

<i>West</i>	<i>North</i>	<i>East</i>	<i>South</i>
—	—	Pass	1 ♣
Pass	1 ♦	Pass	2 ♦
Pass	3NT	All Pass	

With enough to bid twice, North is entitled to bid up the line (though many will skip the diamonds). In the auction shown, South raises diamonds (limiting his hand) and North bids everyone's matchpoint favorite. All roads lead to 3NT on this one (another popular road will be 1 ♣-1 ♥; 2 ♣-3NT). Declarer will need to work on both minors. He has to lose to the ♣Q, but can then force an entry to dummy with the diamonds. Meanwhile, the defense can take at most the two top spades and the two minor-suit winners. 3NT making three should be the most common result, and it is dead average.

Board 19

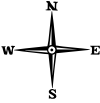
Dealer: S Vul: E-W	♠ 952 ♥ 876 ♦ J107 ♣ 10643		♠ AQ6 ♥ AKQ92 ♦ A6 ♣ K95
♠ 1087 ♥ 10 ♦ K543 ♣ AQ872	♠ KJ43 ♥ J543 ♦ Q982 ♣ J		

MATCHPOINT TABLE	
N-S Score	Match-points
...	100
300	99
200	94
100	88
...	84
-600	79
-620	76
-630	69
-650	62
-660	48
-680	34
-690	22
-720	8
-800	7
...	6
-1370	5
-1390	4
...	3
-1440	2
-1470	1
...	0

<i>West</i>	<i>North</i>	<i>East</i>	<i>South</i>
—	—	—	Pass
Pass	Pass	2♣	Pass
3♣	Pass	3♥	Pass
3NT	Pass	4♣	Pass
4♦	Pass	4NT	Pass
5♣	Pass	5♦	Pass
6♦	Pass	7♣	All Pass

I went a little high-tech here — see if you like these explanations. 2♣: East too strong for anything else. 3♣: Best chance to show the decent club suit. 3♥: Look for the major-suit fit at matchpoints. 3NT: Not clear with a poor spade stopper. 4♣: To show the support. 4♦: Control in diamonds. 4NT: RKC with clubs trump. 5♣: one key card (using 1430 — can't be four in this auction). 5♦: Asking for the ♣Q. 6♦: I have the ♣Q and the ♦K. 7♣: This should have good play. The final contract is decent, but requires 3-2 trumps as a starting point. Yes, declarer can pick up trumps (with a lucky guess), but wouldn't (and even if he did he can't also ruff a diamond in dummy). There are too many things lying badly for any grand slam to make, but still, the auction was fun. The good news is that small slams are also likely to fail (though they can make). In real life, it's not a good idea to push to a so-so grand slam in a duplicate game (unless it is an all-expert field).

Board 20

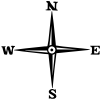
Dealer: W Vul: Both	♠ AK54 ♥ 97 ♦ 986 ♣ K842		♠ 1032 ♥ AK43 ♦ 104 ♣ J1095
	♠ 96 ♥ QJ652 ♦ AQ75 ♣ A3		♠ QJ87 ♥ 108 ♦ KJ32 ♣ Q76

MATCHPOINT TABLE	
N-S Score	Match-points
...	100
200	99
...	98
100	97
0	95
...	94
-100	93
-110	92
-120	91
-140	87
-150	84
-170	54
-180	24
-200	22
...	19
-620	9
-650	1
...	0

<i>West</i>	<i>North</i>	<i>East</i>	<i>South</i>
1♥	Pass	3♥	Pass
4♥	Pass	Pass	Pass

I know — the 3♥ bid is pushy — but I think East is worth the upgrade to a limit raise. He has 8 very nice HCP with beautiful trump support. The doubleton is surely worth a point and I'm adding one more for the club-sequence to get to 10. West also is shown taking the high road to reach what is a bit below a 50-50 game. Declarer needs the ♦K right (or a diamond lead) and no horrible breaks in the red suits. Everything is friendly enough, so the North-South pairs who are unlucky enough to face the auction above will get an undeserved near-bottom. Even 3♥ making four (which takes a tiny bit of declarer skill) is only about average.

Board 21

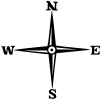
Dealer: N	♠ 1094	
Vul: N-S	♥ 865	
	♦ K97	
	♣ J964	
♠ 85		♠ QJ2
♥ KQJ9		♥ 10743
♦ Q1032		♦ A54
♣ A83		♣ KQ7
	♠ AK763	
	♥ A2	
	♦ J86	
	♣ 1052	

MATCHPOINT TABLE	
N-S Score	Match-points
...	100
300	99
...	97
100	93
...	88
50	64
-90	40
-100	39
-110	38
-120	30
-140	17
-150	10
-170	10
-200	8
...	6
-400	5
-420	4
-430	3
-500	2
...	0

<i>West</i>	<i>North</i>	<i>East</i>	<i>South</i>
—	Pass	1 ♣	1 ♠
Dbl	Pass	2 ♥	Pass
4 ♥	Pass	Pass	Pass

As usual, I'm showing an opening bid with a 12-count. If there were a really ugly 12, I might show a pass. After South's overcall, West has a textbook negative double. I have no problem at all if East wants to eschew his four-card heart suit and rebid 1NT (the hand looks so notrumpy). If he does, he'll play in notrump and take only eight tricks (West might only invite with 2NT if the pair opens flat 12's). If East rebids 2♥ as shown, West has enough to go to game. Declarer has to guess diamonds just to hold it to down one. I guess 12 opposite 12 isn't always a game.

Board 22

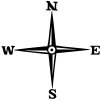
Dealer: E Vul: E-W	♠ 852 ♥ 1053 ♦ A9 ♣ A9852		♠ 6 ♥ Q76 ♦ Q65432 ♣ 643
♠ KQ97 ♥ J4 ♦ J8 ♣ KQJ107	♠ AJ1043 ♥ AK982 ♦ K107 ♣ —		

<i>West</i>	<i>North</i>	<i>East</i>	<i>South</i>
—	—	Pass	1 ♠
2 ♣	2 ♠	Pass	4 ♠
Pass	Pass	Pass	

MATCHPOINT TABLE	
N-S Score	Match-points
...	100
1400	99
1100	98
880	97
800	96
790	95
590	96
500	94
450	92
420	82
...	71
200	69
170	63
150	58
140	53
120	48
110	46
100	45
-50	31
-100	12
-150	4
-200	3
...	2
-300	1
...	0

West's overall is a bit aggressive, but his suit is very good. North could play for a penalty, but I prefer to get in the major-suit raise. South could look for hearts (maybe a 5-4 fit) but that gives away information to the defense, so I show a straight-forward jump to game (with a void in the opponent's suit, he is worth it). Surely, some West players will double, but that shouldn't really show spades/penalty; it shows something like extra values with short spades (for example, ♠x ♥AJx ♦AJx ♣KQJxxx). If East sees it that way, East-West will go for quite a number (and you see some of them on the score sheet). Double-dummy, 4 ♠ can be made, but in real life, it will fail.

Board 23

Dealer: S	♠ AJ974	
Vul: Both	♥ Q4	
	♦ J10652	
	♣ J	
♠ K103	♠ —	♠ —
♥ K108653	♥ A7	♥ A7
♦ 8	♦ KQ74	♦ KQ74
♣ 1095	♣ KQ87643	♣ KQ87643
	♠ Q8652	
	♥ J92	
	♦ A93	
	♣ A2	

<i>West</i>	<i>North</i>	<i>East</i>	<i>South</i>
—	—	—	Pass
Pass	1 ♠	2 ♣	4 ♠
Pass	Pass	4NT	Pass
5 ♣	Pass	Pass	Dbl
Pass	Pass	Pass	

MATCHPOINT TABLE	
N-S Score	Match- points
...	100
850	99
790	98
...	97
620	95
600	93
500	92
400	91
300	89
200	83
170	78
140	76
110	74
100	70
...	66
-100	62
-110	56
-130	54
-140	52
-150	47
-170	41
-200	37
...	34
-500	32
-600	22
-620	12
-650	11
...	10
-750	5
...	0

There are many options here. South can open light. West can open 2♥ (but has a poor suit for second seat vulnerable). North can open light in third seat (as shown). At some tables it could go Pass-Pass-Pass to East who will open 1♣. South could then overcall 1♠ which North would raise to 4♠. On any of these auctions, East has too much playing strength to pass 4♠. The 4NT bid shown is takeout (suggesting long clubs and another suit). West chooses clubs and in the diagram, South would double in spite of partner opening in third seat. The problem is South can't set it. He gets only his two aces (declarer can set up the hearts). The par result is for North-South to sacrifice in 5♠ doubled down one (if declarer guesses very well).

Board 24

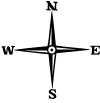
Dealer: W Vul: None	♠ J10864 ♥ AJ ♦ AKJ62 ♣ 5	♠ Q732 ♥ K732 ♦ 1093 ♣ K3
♠ A9 ♥ 864 ♦ Q874 ♣ A842		
	♠ K5 ♥ Q1095 ♦ 5 ♣ QJ10976	

MATCHPOINT TABLE	
N-S Score	Match-points
...	100
460	99
430	97
420	94
400	89
...	84
180	83
170	82
150	79
140	71
130	64
120	62
110	55
90	48
...	47
-50	34
-100	13
-150	3
...	0

<i>West</i>	<i>North</i>	<i>East</i>	<i>South</i>
Pass	1 ♠	Pass	1NT
Pass	2 ♦	Pass	2 ♠
Pass	Pass	Pass	

South doesn't have enough for a two-level response (especially using 2/1 GF). North has an easy 2♦ rebid, and South has three choices: 1) 2♠ (as shown) 2) 2NT 3) 3♣. Choice No. 2 is an overbid (2NT is invitational) and choice No. 3 doesn't seem matchpoint savvy; the money is in the majors. East might lead a trump (to try to stop diamond ruffs in dummy), but his trump holding isn't attractive to lead from. Also his diamonds are poor enough that declarer might not need to do too much ruffing in dummy. On the other hand, East doesn't exactly have any attractive leads. This is a tough deal to play and defend with many guesses at various points for all players involved. Even if it were played in exactly 2♠ at every table in your section, I'd bet that no table had the exact same trick-by-trick play and defense as any other.

Board 25

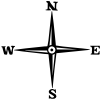
Dealer: N	♠ A8532	
Vul: E-W	♥ 42	
	♦ K107	
	♣ AK3	
♠ 6		♠ 974
♥ J10953		♥ KQ
♦ Q8653		♦ AJ942
♣ Q8		♣ J52
	♠ KQJ10	
	♥ A876	
	♦ —	
	♣ 109764	

MATCHPOINT TABLE	
N-S Score	Match-points
...	100
980	99
...	96
500	95
490	93
480	87
450	58
430	34
420	25
400	16
...	15
210	14
200	13
180	12
170	11
...	10
-50	6
-100	1
...	0

<i>West</i>	<i>North</i>	<i>East</i>	<i>South</i>
—	1♠	Pass	4♦
Pass	4♠	All Pass	

I showed the opening that most players will choose. I'd count the North hand as 15 (adding one for the five-card suit), and because it is balanced, it is possible to open 1NT (though the heart-spade discrepancy is a bit concerning). If North does open 1NT, South will use Stayman, leading to the normal spade game. After the more popular 1♠, South is worth a splinter bid of 4♦ as shown. North's ♦K is wasted (if it were the ♥K he might be interested), so he signs off in the spade game. On the likely heart lead, the defense establishes a trick to take when in with the third club. This looks like 450 for North-South at most tables.

Board 26

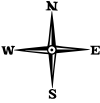
Dealer: E Vul: Both	♠ J53 ♥ Q98 ♦ QJ6 ♣ Q1063	♠ 8 ♥ A42 ♦ K873 ♣ KJ872
♠ AQ1072 ♥ K10763 ♦ A10 ♣ A		
	♠ K964 ♥ J5 ♦ 9542 ♣ 954	

MATCHPOINT TABLE	
N-S Score	Match-points
...	100
300	99
...	98
200	95
100	85
...	78
-200	75
-230	73
-600	66
-620	57
-630	47
-650	32
-660	21
-680	13
-690	6
-1430	3
...	0

<i>West</i>	<i>North</i>	<i>East</i>	<i>South</i>
—	—	Pass!	Pass
1♠	Pass	1NT	Pass
3♥	Pass	3NT	Pass
??			

Why (all of a sudden) no light opening? East's hand is borderline, but I recommend passing because of the rebid problem. If East opens 1♦, he is prepared to rebid 2♣ over a likely 1♠ response, but that distorts the minor-suit length. If East opens 1♣ and partner responds 1♠ the rebid problem is hideous. So, why bother to get involved? Pass is not a dirty word. After West's 1♠, East bids 1NT (2♣ would be Drury for most) which shows up to 11 points. West's 3♥ (game forcing) is a stretch, but he has nice shape and good 10s. East has a little in reserve for 3NT (but he expects a misfit). West's hand looks okay for notrump, so he might pass (or he can bid 4♥ to show the fifth heart — in which case 4♥ will be the final contract). The hand plays much better in hearts because declarer can ruff spades in dummy. With a rosy view (spade finesse), 12 tricks can be taken in hearts for most of the matchpoints.

Board 27

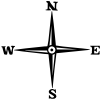
Dealer: S Vul: None	♠ Q9654 ♥ 854 ♦ J10 ♣ AKQ	♠ K2 ♥ K732 ♦ AKQ72 ♣ 105
♠ A8 ♥ A109 ♦ 8543 ♣ J873		
	♠ J1073 ♥ QJ6 ♦ 96 ♣ 9642	

MATCHPOINT TABLE	
N-S Score	Match-points
...	100
300	99
...	98
50	94
-50	90
-100	83
-110	77
-130	53
-140	29
-150	23
-170	17
...	16
-300	14
-400	11
-420	7
-430	6
-450	5
-460	4
...	3
-500	1
...	0

<i>West</i>	<i>North</i>	<i>East</i>	<i>South</i>
—	—	—	Pass
Pass	1 ♠	Dbl	3 ♠
??			

East could overcall in diamonds, but doubling with this hand-type (long diamonds and the other major) is permissible under the “ELCD” concept. This stands for “Equal Level Conversion Double” and means that doubling a major and then converting a club takeout to diamonds doesn’t promise a strong (17-plus) type of hand. South’s preemptive 3 ♠ is a bit sick, but possibly effective. He has four trumps, but the shape isn’t great and the Q-J-x in what could easily be the opponents’ suit is concerning. West could scrape up a responsive double or East might reopen, but it is quite possible that 3 ♠ will steal the pot at only 50 a trick. The defense can take six top tricks, but won’t score well for plus 100 on this deal. East-West have an easy partscore in diamonds, but can actually make a game. 4 ♥ in the 4-3 fit is a lucky make, but who could argue with 3NT — which is laydown? Maybe South’s bidding isn’t as sick as I labeled it.

Board 28

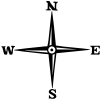
Dealer: W Vul: N-S	♠ J2 ♥ 10432 ♦ J102 ♣ J754	♠ Q103 ♥ Q8765 ♦ KQ64 ♣ 3
♠ A9875 ♥ AK9 ♦ 3 ♣ Q986		♠ K64 ♥ J ♦ A9875 ♣ AK102

MATCHPOINT TABLE	
N-S Score	Match-points
...	100
500	99
...	98
200	97
...	96
110	94
100	82
50	53
-110	34
-140	29
-170	24
-200	21
-420	12
-430	4
-450	3
-480	2
-500	1
...	0

<i>West</i>	<i>North</i>	<i>East</i>	<i>South</i>
1 ♠	Pass	2 ♠	2NT
Pass	3 ♣	3 ♥	Pass
3 ♠	Pass	Pass	Pass

If available, East might consider 1NT followed by 3♠ to show a three-card limit raise. Over only 2♠, South should get into the auction. With a singleton heart he can't double, but he can bid 2NT for a two-suiter (presumed to be minors) as shown. West has nothing to say for the moment, and North chooses 3♣. East has no interest in defending with a singleton, so bids again. On the way to 3♠ he might as well show the hearts in case that turns West on. West has a nice hand, but not enough for game opposite a single raise. The defense is entitled to both minor-suit aces and a spade trick. Anything else? Probably a trick (maybe two tricks?) in the wash; the deal gets complicated by the 4-1 heart break.

Board 29

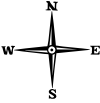
Dealer: N Vul: Both	♠ AJ1072 ♥ 64 ♦ KJ104 ♣ 54	♠ 54 ♥ Q82 ♦ 975 ♣ AK732
♠ Q86 ♥ J753 ♦ A2 ♣ QJ106		
	♠ K93 ♥ AK109 ♦ Q863 ♣ 98	

MATCHPOINT TABLE	
N-S Score	Match-points
...	100
620	97
500	95
0	94
200	93
170	69
140	33
130	21
120	18
110	16
100	13
90	10
0	8
-100	4
-200	1
...	0

<i>West</i>	<i>North</i>	<i>East</i>	<i>South</i>
—	Pass	Pass	1♦
Pass	1♠	Pass	Pass
Dbl	2♠	3♣	Pass
Pass	??		

The auction starts slowly, but then gets competitive. South can pass partner's 1♠ (because North is a passed hand). West has the unbid suits and might scrape up a takeout double as shown. North has no interest in defending on the two level, so he repeats his suit. East comes to life with 3♣, but North might not be finished. Actually, passing 3♣ is a winner since the defense can beat it two tricks for the magical matchpoint 200. In spades, North-South do well, likely making 10 tricks with a trump guess (though this auction might produce a misguess).

Board 30

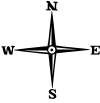
Dealer: E Vul: None	♠ J542 ♥ J106 ♦ AJ ♣ AJ108	♠ KQ8 ♥ K32 ♦ KQ632 ♣ 32
♠ A10976 ♥ Q98 ♦ 108 ♣ 965		
	♠ 3 ♥ A754 ♦ 9754 ♣ KQ74	

MATCHPOINT TABLE	
N-S Score	Match-points
...	100
150	97
140	95
130	94
120	93
110	92
100	85
90	79
50	59
-50	39
-90	36
-100	35
-110	18
-130	2
-140	1
...	0

<i>West</i>	<i>North</i>	<i>East</i>	<i>South</i>
—	—	1♦	Pass
1♠	Pass	2♠	Pass
Pass	Pass		

East could rebid 1NT, but with a low side doubleton and three low trumps, I prefer raising. Yes, it could be a 4-3 fit, but that feels better than rebidding 1NT. North-South are shown going quietly; perhaps South could stick his neck out with a double after the raise to 2♠. Even with the bad spade break, West is likely to make his contract. In fact, the opening lead of the ♥J will be quite helpful. As usual, two of a major making two is a great matchpoint score and will leave North-South wondering what they should have done differently. The matchpoint table has no score higher than 150 — the lowest high score for the session.

Board 31

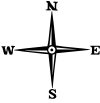
Dealer: S	♠ 754	
Vul: N-S	♥ J84	
	♦ KQ5	
	♣ QJ107	
♠ AK1082		♠ Q93
♥ 3		♥ AKQ7
♦ A1072		♦ 964
♣ A93		♣ 642
	♠ J6	
	♥ 109652	
	♦ J83	
	♣ K85	

MATCHPOINT TABLE	
N-S Score	Match-points
...	100
100	98
50	96
-140	94
-170	92
-180	90
-400	89
-420	80
-430	64
-450	29
-460	3
...	0

<i>West</i>	<i>North</i>	<i>East</i>	<i>South</i>
—	—	—	Pass
1♠	Pass	1NT	Pass
2♦	Pass	3♠	Pass
4♠	Pass	Pass	Pass

I like 1NT to be semi-forcing (if West passes, life goes on and 1NT might be better than three of the major). Here, West won't pass any kind of 1NT response; he bids 2♦. East can now complete the limit raise, and West has an easy continuation to the spade game. The ♣Q lead jumps out of North's hand and declarer will win and throw club losers on hearts. When trumps split and diamonds break 3-3, all roads lead to 11 tricks. Honestly, this deal should be a flat 450, but I know there is no such thing. I suppose some East-Wests will play in 3NT where there are only 10 tricks if the defense gets around to clubs (or 11 if they don't).

Board 32

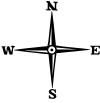
Dealer: W	♠ 97	
Vul: E-W	♥ Q93	
	♦ K85	
	♣ 109642	
♠ 62		♠ AK853
♥ A52		♥ J74
♦ QJ97643		♦ A10
♣ 7		♣ AQ5
	♠ QJ104	
	♥ K1086	
	♦ 2	
	♣ KJ83	

MATCHPOINT TABLE	
N-S Score	Match-points
...	100
400	98
300	93
200	80
100	54
-120	37
-140	35
-150	33
-600	28
-620	24
-630	16
-660	7
-690	3
-750	1
...	0

West *North* *East* *South*
 3♦ Pass 3♠ Pass
 ??

It's aggressive to preempt at these colors without a good hand/suit, but depending on personal style, West might have enough. East could try spades as he heads towards 5♦. Should West raise on a doubleton (with a side ace and side ruffing value)? Maybe. The hand plays poorly in 4♠. 5♦ has more chances, but there look like just too many obstacles for declarer to come to 11 tricks.

Board 33

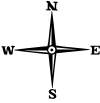
Dealer: N Vul: None	♠ KJ102 ♥ AJ94 ♦ 972 ♣ K8	♠ Q7 ♥ K6 ♦ QJ654 ♣ J942
♠ A98643 ♥ 108 ♦ A3 ♣ A63		
	♠ 5 ♥ Q7532 ♦ K108 ♣ Q1075	

<i>West</i>	<i>North</i>	<i>East</i>	<i>South</i>
—	Pass	Pass	1♣
Pass	1♥	1♠	Dbl*
2♠	3♣	Pass	Pass
Pass			

* Support Double

MATCHPOINT TABLE	
N-S Score	Match-points
...	100
500	99
...	96
460	95
...	94
430	93
...	91
400	85
300	84
...	80
210	78
200	74
180	71
170	68
150	50
140	49
130	46
120	31
110	29
100	26
...	19
50	17
...	12
-50	5
...	4
-100	3
-110	1
...	0

The auction shown needs little explanation and looks quite standard all around. If North-South don't know support doubles, South would have to choose between 1NT or 2♥ (or pass). With the club finesse onside, South can take 11 tricks in his club partscore. Pairs reaching the 4-3 heart fit will also fare well, but the play (as usual in a Moysian fit) is complex. The normal contract taking the normal number of tricks produces ... drumroll ... 50%.

Board 34

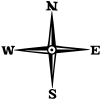
Dealer: E		♠ 4	
Vul: N-S		♥ Q1096	
		♦ 1092	
		♣ AQJ97	
♠ J93			♠ AQ1076
♥ 75			♥ A843
♦ QJ754			♦ 863
♣ K42			♣ 8
			♠ K852
			♥ KJ2
			♦ AK
			♣ 10653

MATCHPOINT TABLE	
N-S Score	Match-points
...	100
500	99
...	98
150	96
140	95
...	94
120	92
110	91
100	86
50	71
...	60
-100	57
-110	38
...	21
-140	14
-170	6
-200	3
...	2
-470	1
...	0

<i>West</i>	<i>North</i>	<i>East</i>	<i>South</i>
—	—	Pass	Pass
1♠	Pass	1NT	Pass
2♠	Pass	Pass	Dbl
Pass	??		

The first two rounds of bidding are fairly normal (though East could overbid with 2NT at his second turn). South's reopening double is dangerous, but I approve. If he takes a shot at passing, North will be quite disappointed by dummy (extras and the ♠Q). If North bids 3♥ he might buy it there. If 3♥ is down only one (undoubled), North-South will get an above average result. Better North-South matchpoint awards come when East-West get too high.

Board 35

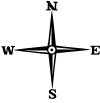
Dealer: S Vul: E-W	♠ KJ72 ♥ K104 ♦ AKQ6 ♣ A5	♠ 105 ♥ Q2 ♦ 8742 ♣ KJ876
♠ A ♥ J753 ♦ J53 ♣ Q10432		
	♠ Q98643 ♥ A986 ♦ 109 ♣ 9	

MATCHPOINT TABLE	
N-S Score	Match-points
...	100
990	99
980	94
...	92
480	73
460	58
450	39
430	19
420	18
...	17
-50	11
-100	4
-150	3
-200	2
...	0

<i>West</i>	<i>North</i>	<i>East</i>	<i>South</i>
—	—	—	Pass
Pass	2NT	Pass	3♣
Pass	3♠	Pass	4♠
Pass	Pass	Pass	

After 2NT, South could ignore the hearts and just transfer (maybe with Texas) to spades. Bidding Stayman seems better since the hand could easily belong in hearts. If North doesn't bid hearts, South can still reach 4♠. When North surprisingly bids spades, South might momentarily consider slam. Slam is actually on the 50-50 diamond finesse. With the ♦J onside, declarer can take five spades, two hearts, four diamonds and the ♣A for 12 tricks. Even in game (the likely spot), declarer should take the diamond finesse (nothing to lose) for 480 and a good score.

Board 36

Dealer: W
Vul: Both

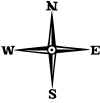
<p>♠ 8732 ♥ 965 ♦ AKJ10 ♣ K10</p>	<p>♠ 5 ♥ J73 ♦ Q743 ♣ J7542</p>		<p>♠ Q104 ♥ Q82 ♦ 82 ♣ Q9863</p>
<p>♠ AKJ96 ♥ AK104 ♦ 965 ♣ A</p>			

MATCHPOINT TABLE	
N-S Score	Match-points
...	100
650	99
630	97
620	95
600	92
...	91
200	88
...	87
170	73
...	60
140	44
...	28
110	19
...	10
-100	6
...	3
-200	2
-300	1
...	0

<i>West</i>	<i>North</i>	<i>East</i>	<i>South</i>
Pass	Pass	Pass	1♠
Pass	Pass	Pass	

Some Wests (assuming anyone actually plays Board 36) might love their diamond holding enough to open the bidding. If not, South will open 1♠, and I see no reason for anyone to disturb this. The cards are quite friendly for North-South who rate to make any partscore they bid.



Wrap-Up – Statistics

Thank you for taking this journey with me — I hope that even if you didn't have a good game, that you enjoyed reading what could have been. A true student of the game might consider reading about not only the (approximately) 24 deals he played, but the other deals in the booklet as well. I feel that there is something to learn from each and every of the 36 deals presented here. (I can't recall ever seeing a deal where there wasn't some educational point that could be made). Especially for intermediate or lower players, please make sure you understand all the discussion of what is "normal" and what is not.

This year there were a lot of non-competitive auctions (one side had all the cards). As usual with such deals, you were often at the mercy of your opponents when they had the cards. No matter how skillfully you played, you needed decent luck on the boards where you didn't have the cards. Without good luck, it would be hard to score more than 60% on this set. There was very little need for conventions on this (nor most) set of boards.

Since there is always griping about the computer-dealt hands, here are some statistics regarding the 36 deals:

	NORTH	SOUTH	EAST	WEST
Avg HCP	9.64	10.42	10.36	9.58
Total # Singletons	10	15	9	14
Total # of Voids	1	4	2	1
Total # of 7+ card suits	0	0	1	2
Total # of "balanced" hands	19	16	19	16

Mathematicians know that the computer is honest. When it deals hands, the result is "normal shape." It is the human-dealt hands (usually with inadequate shuffling of the deck) that cause abnormal and skewed distributions (namely, too many flat hands). South seems likely to have been dealt the most entertainment. Don't get too carried away by these statistics as they cover all 36 deals. Most of you played only 2/3 of these deals — and you might have skipped the 12 where your seat had all the action. Life can be that way.





American Contract Bridge League

6575 Windchase Blvd.

Horn Lake, MS 38637-1523

662-253-3100

www.acbl.org

© 2012 ACBL. Printed in the USA by ACBL.